

【DECLARATION】

Thanks for purchasing the Electronic Speed Controller (ESC). High power system for RC model can be very dangerous, please read this manual carefully. In that we have no control over the correct use, installation, application, or maintenance of our products, no liability shall be assumed nor accepted for any damages, losses or costs resulting from the use of the product. Any claims arising from the operating, failure of malfunctioning etc. will be denied. We assume no liability for personal injury, consequential damages resulting from our product or our workmanship. As far as is legally permitted, the obligation to compensation is limited to the invoice amount of the affected product.

【FEATURES】

- ▶ Compatible with all sensorless brushless motors and most of sensed brushless motors such as LRP, SpeedPassion, Novak, etc.
- ▶ Seamlessly change to sensorless working mode when the sensor cable is broken.
- ▶ Excellent start-up, acceleration and linearity features.
- ▶ Built-in switch mode BEC has a powerful output to supply all the electronic equipments.
- ▶ Firmware can be updated through an USB adapter on the advanced LCD Program Box (Optional equipment).
- ▶ User programmable. Easily programmed with the “SET” button on the ESC and also compatible with the 3 digital LEDs Program Card and the advanced professional LCD Program Box.
 - ◆ 3 running modes (Forward mode, Forward/Reverse mode, Rock Crawler mode)
 - ◆ 4 steps of maximum reverse force adjustment.
 - ◆ Proportional ABS brake function with 5 steps of maximum brake force adjustment, 8 steps of drag-brake force adjustment and 4 steps of initial brake force adjustment.
 - ◆ 9 start modes (Also called “Punch”) from “very soft (Level 1)” to “very aggressive (Level 9)”.
 - ◆ 8 steps of timing adjustment to suitable for all brushless motors.
 - ◆ Multiple protection features: Low voltage cut-off protection / Over-heat protection / Throttle signal loss protection / Motor blocked protection.
- ▶ Compatible with traditional mechanical disc-brake system.
- ▶ Splash proof and dustproof.

【SPECIFICATIONS】

Model	80A	150A
Cont./ Burst Current	80A / 380A	150A/950A
Resistance	0.0006 ohm	0.0002 ohm
Suitable Car	1/8 on-road, off-road and monster RTR applications	1/5, 1/8 on-road, off-road and monster Super powerful applications
Suitable Motor	Sensored and sensorless Brushless Motors	
	≥6T, KV≤2400 The 80A ESC works with 4S Lipo	≥4.5T, KV≤3000 (Works with 4S Lipo) ≥6T, KV≤2400 (Works with 6S Lipo)
Battery	6-12 cells NiMH or 2-4 cells Li-Po	6-18 cells NiMH or 2-6 cells Li-Po
BEC Output	5.75V@3A Switch mode built-in BEC	
Dimension	58mm(L) * 46.5mm(W) * 35mm(H)	
Weight	105g (Wires not included)	
Cooling Fan Working Voltage	5V, maximum 8V. (The fan gets the power supply from the built-in BEC)	

【BEGIN TO USE THE NEW ESC】

WARNING! THIS BRUSHLESS SYSTEM IS VERY POWERFUL! FOR SAFETY, PLEASE ALWAYS KEEP THE WHEELS AWAY FROM THE TRACK WHEN YOU BEGIN TO SWITCH ON THE ESC.

1. Connect The ESC, Motor, Receiver, Battery And Servo

A) Sensored brushless motor wiring

When using brushless motor with Hall Sensor, it is necessary to connect the sensor cable to the “SENSOR” port on the ESC, and ESC can automatically identify the motor type (sensored or sensorless) by detecting the signal coming from the SENSOR port.

WARNING! For sensored brushless motor, the #A, #B, #C wires of the ESC MUST be connected with the motor wire #A, #B, #C respectively. Do not change the wires sequence optionally!

B) Sensorless brushless motor wiring

When using brushless motor without Hall Sensor, the #A, #B, #C wires of the ESC can be connected with the motor wires freely (without any sequence). If the motor runs in the opposite direction, please swap any two wire connections.

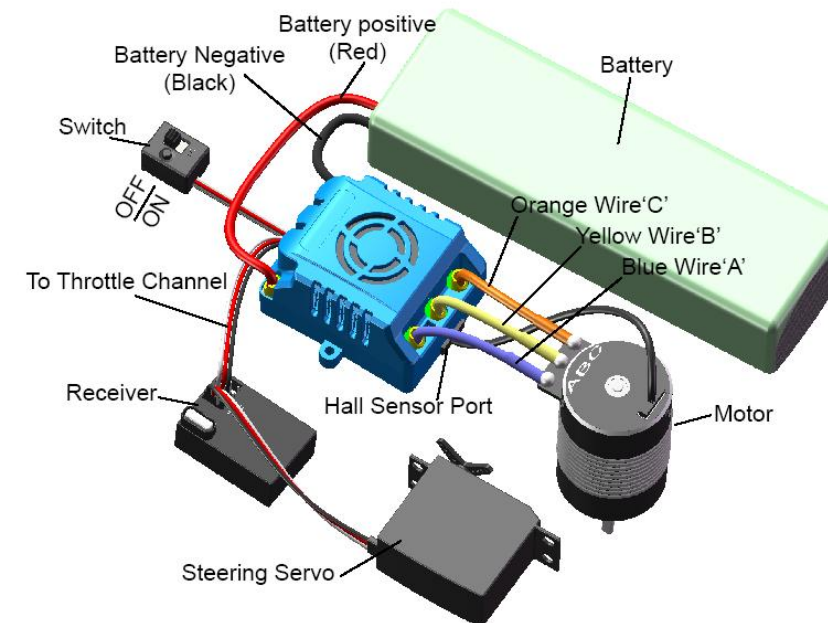

If there are 2 battery packs need to be connected in series, please refer to the following picture:

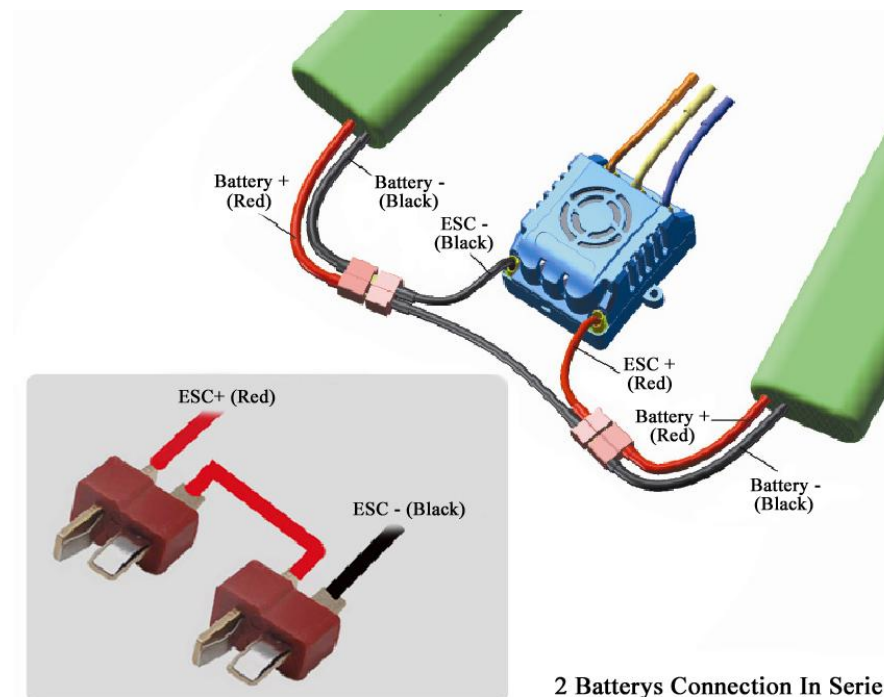

2 Batterys Connection In Series

2. Throttle Range Setting (Throttle Range Calibration)

In order to make the ESC fit the throttle range, you must calibrate it when you begin to use a new ESC, or a new transmitter, or change the settings of neutral position of the throttle stick, ATV or EPA parameters, etc. Otherwise the ESC cannot work properly.

There are 3 points need to be set, they are “Top point of forward”, “Top point of backward” and the neutral point. The following pictures show how to set the throttle range with a Futaba™ transmitter.

- A) Switch off the ESC, turn on the transmitter, set the direction of throttle channel to “REV”, set the “EPA/ATV” value of throttle channel to “100%”, and disable the ABS function of your transmitter.
- B) Hold the “SET” key and then switch on the ESC, and release the “SET” key as soon as possible when the red LED begins to flash. (Note2)

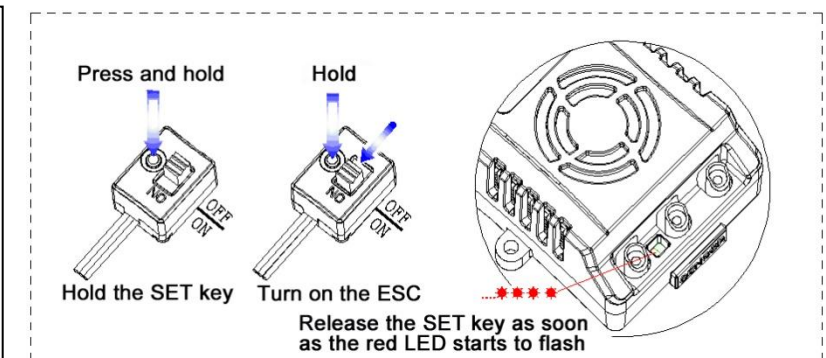

Note2: If you don't release the “SET” key as soon as the red LED begins to flash, the ESC will enter the program mode, in such a case, please switch off the ESC and re-calibrate the throttle range again from step A to step D.

- C) Set the 3 points according to the steps shown as the pictures on the right side.
- 1) **The neutral point**
Move the throttle stick at the neutral point, and then click the SET key, the green LED flashes 1 time.
 - 2) **The end point of forward direction**
Move the throttle stick at the end point of forward direction, and then click the SET key, the green LED flashes 2 times.
 - 3) **The end point of backward direction**
Move the throttle stick at the end point of backward direction, and then click the SET key, the green LED flashes 3 times.
- D) Throttle range is calibrated; motor can be started after 3 seconds.

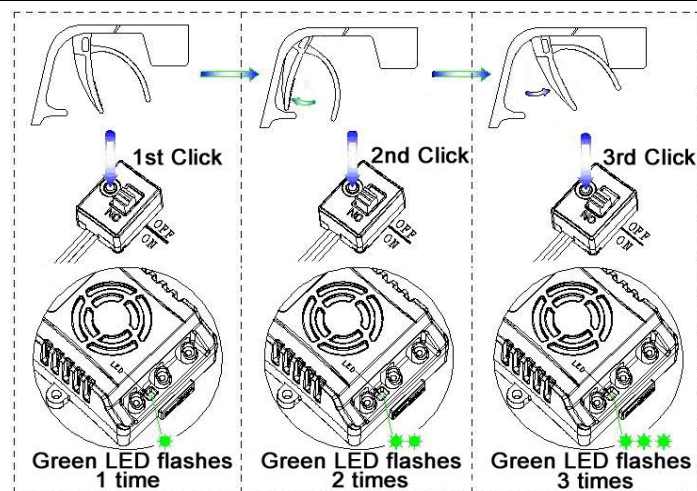

3. Check The LED Status In Normal Running

- ▶ Normally, if the throttle stick is in the neutral range, neither the red LED nor the green LED lights.
- ▶ The red LED lights when the car is running forward or backward and it will flash quickly when the car is braking.
- ▶ The green LED lights when the throttle stick is moved to the top point of the forward zone.

4. Check The Lipo Cells Setting If You Are Using Lithium Battery

If you are using Lipo battery, we strongly suggest setting the "Lipo Cells" programmable item manually to avoid the over-discharge problem. Please read the instructions on page 3.

In normal case, when the ESC is switched on, the motor will emit several "Beep" tones to express the cells amount of the battery pack. For example, "Beep-Beep-" means 2s Lipo, "Beep-Beep-Beep-" means 3s Lipo, etc.

【PROGRAM THE ESC】

1. Programmable Items List *(The italics texts in the form are the default settings)*

Programmable Items	Options								
	1	2	3	4	5	6	7	8	9
Basic Items									
1. Running Mode	Forward with Brake	<i>Forward/Reverse with Brake</i>	Forward and Reverse						
2. Drag Brake Force	<i>0%</i>	5%	10%	20%	40%	60%	80%	100%	
3. Low Voltage Cut-Off Threshold	Non-Protection	2.6V/Cell	2.8V/Cell	3.0V/Cell	<i>3.2V/Cell</i>	3.4V/Cell			
4. Start Mode(Punch)	Level1	Level2	Level3	Level4	<i>Level5</i>	Level6	Level7	Level8	Level9
Advanced Items									
5. Max Brake Force	25%	50%	<i>75%</i>	100%	Disable				
6. Max Reverse Force	<i>25%</i>	50%	75%	100%					
7. Initial Brake Force	<i>= Drag Brake Force</i>	0%	20%	40%					
8. Neutral Range	6% (Narrow)	<i>9% (Normal)</i>	12% (Wide)						
9. Timing	0.00 °	3.75 °	7.50 °	11.25 °	<i>15.00 °</i>	18.75 °	22.50 °	26.25 °	
10. Over-heat Protection	<i>Enable</i>	(The over-heat protection function is permanently enabled by the manufacturer)							
11. Motor Rotation	<i>Counter Clockwise</i>	Clockwise							
12. Lipo Cells	<i>Auto Calculate</i>	2 Cells	3 Cells	4 Cells	5 Cells	6 Cells			

2. Explanation For Each Programmable Item

2.1. **Running Mode:** With "Forward with Brake" mode, the car can go forward and brake, but cannot go backward, this mode is suitable for competition; "Forward/Reverse with Brake" mode provides backward function, which is suitable for daily training.

Note: "Forward/Reverse with Brake" mode uses "Double-click" method to make the car go backward. When you move the throttle stick from forward zone to backward zone for the 1st time (The 1st "click"), the ESC begins to brake the motor, the motor speeds down but it is still running, not completely stopped, so the backward action is NOT happened immediately. When the throttle stick is moved to the backward zone for the 2nd time (The 2nd "click"), if the motor speed is slowed down to zero (i.e. stopped), the backward action will happen. The

"Double-Click" method prevents mistaken reversing action when the brake function is frequently used in steering. By the way, in the process of brake or reverse, if the throttle stick is moved to forward zone, the motor will run forward at once.

"Forward/Reverse" mode uses "Single-click" method to make the car go backward. When you move the throttle stick from forward zone to backward zone, the car will go backward immediately. This mode is usually used for the Rock Crawler.

2.2. **Drag Brake Force:** Set the amount of drag brake applied at neutral throttle to simulate the slight braking effect of a neutral brushed motor while coasting.

2.3. **Low Voltage Cut-Off:** The function prevents the lithium battery pack from over discharging. The ESC detects the battery's voltage at any time, if the voltage is lower than the threshold for 2 seconds, the output power will be reduced 70%, after 10 seconds the output will be completely stopped, and the red LED flashes in such a way: "☆-☆-, ☆-☆-, ☆-☆-".

There are 6 preset options for this item. You can customize the cutoff threshold by using an advanced LCD program box (optional equipment) to trim it with a step of 0.1V, so it will be more suitable for all kinds of batteries (NiMH, NiCd, Li-ion, Lipo, LFP, etc). **Please always keep in mind that the customized value is not for each cell, it is for the WHOLE battery pack.**

2.4. **Start Mode (Also called "Punch"):** Select from "Level1" to "Level9" as your like, Level1 has a very soft start effect, while level9 has a very aggressive start effect. From Level1 to Level9, the start force is increasing. Please note that if you choose "Level7" to "Level9" mode, you must use good quality battery pack with powerful discharge ability, otherwise these modes cannot get the burst start effect as you want. If the motor cannot run smoothly (the motor is trembling), it may caused by the weak discharge ability of the battery pack, please choose a better battery or increase the gear rate (Use a smaller pinion).

2.5. **Maximum Brake Force:** The ESC provides proportional brake function. The brake force is related to the position of the throttle stick. Maximum brake force refers to the force when the throttle stick is located at the top point of the backward zone. A very large brake force can shorten the brake time, but it may damage the gears. The "Disable" option inhibits the inherent brake function of the speed controller. When this option is selected, the brake function is realized by a traditional disc-brake system driven by a servo.

2.6. **Maximum Reverse Force:** Sets how much power will be applied in the reverse direction. Different value makes different reverse speed.

2.7. **Initial Brake Force:** It is also called "minimum brake force", and it refers to the force when the throttle stick is located at the initial position of the backward zone. The default value is equal to the drag brake force, so the brake effect can be very smoothly.

2.8. **Throttle Neutral Range:** Please refer to the following picture to adjust the neutral range as your like.

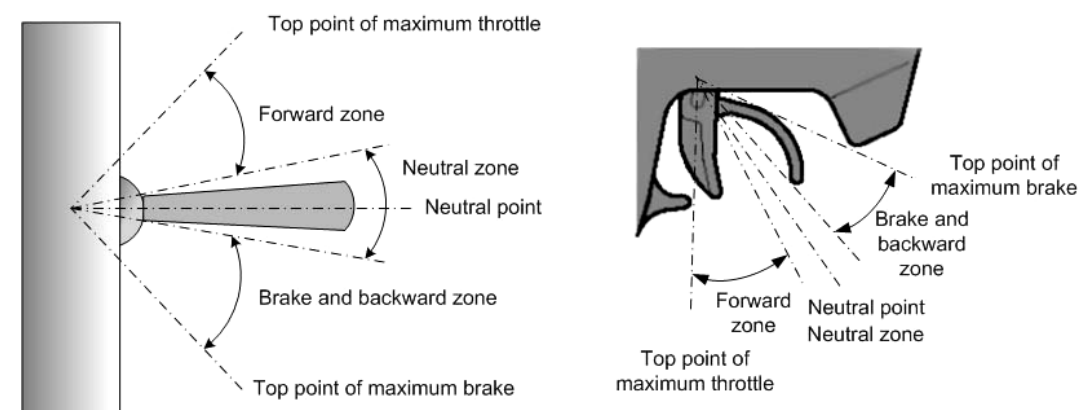

2.9. **Timing:** There are many differences among structures and parameters of different brushless motors, so a fixed timing ESC is difficult to compatible with all brushless motors. It is necessary to make the timing value programmable. Please select the most suitable timing value according to the motor you are just using. Generally, higher timing value brings out higher power output, but the whole efficiency of the system will be slightly lower down.

2.10. **Over-Heat Protection:** If the function is activated, the output power will be cut-off when the temperature of the ESC or the internal temperature of the sensed brushless motor is higher than a factory-preset value for 5 seconds. When the protection happens, the Green LED will flash.

(Note: The over-heat protection function is permanently enabled by the manufacturer).

★ **When the ESC is over-heat:** The Green LED flashes as "☆-, ☆-, ☆-".

★ **When the motor is over-heat:** The Green LED flashes as "☆-☆-, ☆-☆-, ☆-☆-".

Note3: The motor over-heat protection function is only available for the sensed brushless motor made by the

same manufacturer of the ESC. For motors made by other manufacturers, this function maybe not available or the protection point doesn't match the design of the ESC.

2.11. **Motor Rotation:** You can use this item to change the rotation direction. Face to the motor shaft (That means the rear cover of the motor is far from your face), and move the throttle stick to the top point of the forward zone. If this item is set to "CCW", the shaft runs counter-clockwise; If this item is set to "CW", the shaft runs clockwise.

2.12. **Lipo Cells:** We strongly suggest setting the "Lipo Cells" item manually. Because the normal voltage of each Lipo cell varies from 2.6V to 4.2V, it is quite difficult to calculate the cells number of a discharged Lipo battery pack. If it is calculated incorrectly, the Low Voltage Cutoff Protection function may work abnormally, so the option "Auto Calculate" is only available for 2s, 4s and 6s Lipo. If the voltage of the battery pack is lower than 8.8V, it is judged as a 2s Lipo; If the voltage is between 8.8V to 17.6V, it is judged as a 4s Lipo; If the voltage is higher than 17.6V, it is judged as a 6S Lipo. So in order to make the Low Voltage Cutoff Protection function always works correctly, please set the "Lipo Cells" item manually.

3. Program Methods

A) Program the ESC with LED program card (Optional equipment)

Please refer to the user manual of LED program card.

B) Program the ESC with advanced LCD program box (Optional equipment)

Please refer to the user manual of LCD program box.

C) Program the ESC with the SET button on the ESC

Please refer to the instructions at the right side.



4. Reset All Items To Default Values

At any time when the throttle is located in neutral zone (except in the throttle calibration process or ESC program mode), hold the "SET" key for over 3 seconds, the red LED and green LED will flash at the same time , which means each programmable item has be reset to its default value.

【ALERT TONES】

1. Input voltage abnormal alert tone: The ESC begins to check the input voltage when power on, if the voltage is out of the normal range, such an alert tone will be heard: "beep-beep-, beep-beep-, beep-beep-" (There is 1 second interval between every group of "beep-beep-" tone).
2. Throttle signal abnormal alert tone: When the ESC can't detect the normal throttle signal, such an alert tone will be heard: "beep-, beep-, beep-" (There is 2 seconds interval between every "beep-" tone).

Flow chart: Program the ESC with the SET key

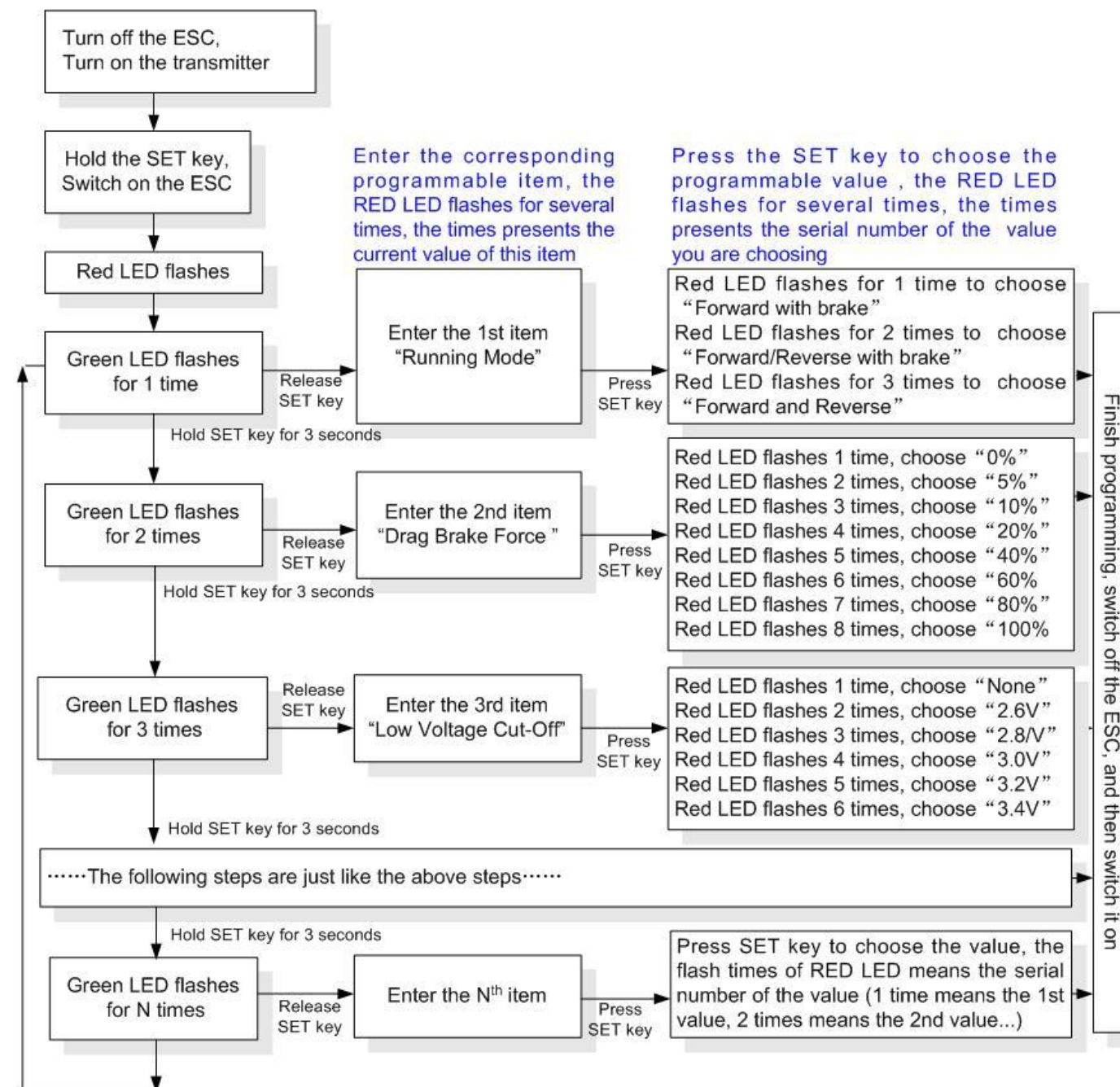

Note4:

- ★ In the program process, when the LED is flashing, the motor will emit "Beep" tone at the same time.
- ★ If the number "N" is bigger than the "5", we use a long time flash and long "Beep---" tone to represent "5", so it is easy to identify the items with bigger series number.

For example, if the LED flashes as the following:

"A long time flash + 1 short time flash" (Motor sounds "Beep---Beep") = the No. 6 item

"A long time flash + 2 short time flashes" (Motor sounds "Beep---BeepBeep") = the No. 7 item

"A long time flash + 3 short time flashes" (Motor sounds "Beep---BeepBeepBeep") = the No. 8 item

.....

And so on.

【MAIN APPLICATIONS】

ESC	Motor	Pinion	Gear Rate	Applications
XERUN -80A	Diameter=40 Length=68 KV=2250	M1, 13T (Truggy / Buggy)	1/8 Off-Road: 10-16 1/8 Monster: 16-21	1/8 EP Off-Road Truggy /Buggy/ Monster RTR. 1/8 NP Off-Road Truggy or Buggy changes to EP. 4 cells Lipo battery is recommended.
XERUN -150A	Diameter=40 Length=68 KV=2250	M1, 13T (Truggy / Buggy) 32Pitch, 19T (Monster)	1/8 Off-Road: 10-15.5 1/8 Monster: 13-21	1/8 EP Truggy / Buggy and Monster. Very powerful and reliable. Brings out incredible speed. 4 cells Lipo battery is recommended.
XERUN -150A	Diameter=42 Length=74 KV=2200 or KV=1800	32 Pitch 4 cells Lipo: 21T 6 cells Lipo: 17T	4 Cells Lipo: 12-19 6 Cells Lipo: 15-21	1/8 EP Monster. Super and crazy powerful. 4 cells or 6 cells Lipo battery is recommended.

【TROUBLE SHOOTING】

Trouble	Possible Reason	Solution
After power on, motor doesn't work, and the cooling fan doesn't work	The connections between battery pack and ESC are not correct	Check the power connections Replace the connectors
After power on, motor can't work, but emits "beep-beep-, beep-beep-" alert tone. (Every group of "beep-beep-" has a time interval of 1 second)	Input voltage is abnormal, too high or too low	Check the voltage of the battery pack
After power on, red LED always lights, the motor doesn't work	Throttle signal is abnormal	Plug the control wire into the throttle channel of the receiver correctly.
The motor runs in the opposite direction when it is accelerated	1)The wire connections between ESC and the motor are not correct 2)The chassis is different from the popular design	1) For sensorless motor: Swap any two wire connections between the ESC and the motor. Or use the method #2 2) For sensored motor: Please check the wire connections, they must be A-A, B-B, C-C respectively. If the connections are correct, please change the "Motor Rotation" programmable item to "CW(Clockwise)"
The motor suddenly stops running while in working state	The throttle signal is lost	Check the transmitter and the receiver Check the signal wire from the throttle channel of your receiver
	The ESC has entered the Low Voltage Protection Mode or Over-heat Protection Mode	Red LED flashing means Low voltage protection. Green LED flashing means Over-heat protection
When accelerating quickly, the motor stops or trembles	1) The battery has a bad discharge performance 2) The gear rate is too small 3) The "Start Mode (Punch)" of the ESC is too aggressive	1) Use a better battery 2) Use lower KV motor or change the gear rate, choose smaller pinion 3) Select a softer option for the "Start Mode (Punch)"
When the throttle stick is in the neutral range, the red LED and the green LED flashes synchronously	The motor is a sensored motor, but the ESC detects abnormal signal from the sensor, so it changes to sensorless mode automatically	1) Check the connection of Hall sensor cable to make it firmly connect the motor with the ESC 2) The Hall sensors in the motor are damaged, please change the motor